



**SMA Female to SMA Female Bulkhead Adapter
DC-27 GHz, VSWR 1.2, For Cryogenic Application**

Electrical

Impedance	50 ohm
Frequency Range	DC-27 GHz
VSWR	1.2 max

Mechanical & Environmental

Connector Body	Non-magnetic beryllium copper, Gold Plated Nickel-free under-plating
Center Contact	Non-magnetic beryllium copper, Gold Plated Nickel-free under-plating
Insulator	PTFE
Net Weight	Approx 5g
Operating Temperature	4 K to +125°C

Dimensions(mm)

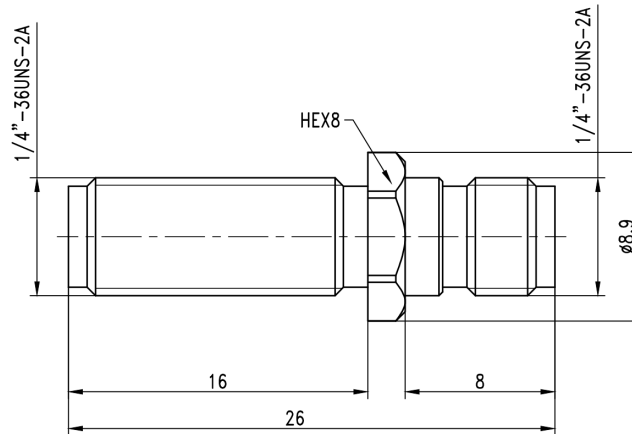

**SMA Female to SMA Female Bulkhead Adapter
DC-27 GHz, VSWR 1.2, For Cryogenic Application**



Typical Test Data

