

## Hermetically Sealed 1.85mm Female to 1.85mm Female Adapter, Bulkhead

### Applications

- Vacuum
- High pressure
- Airtight seal



### Electrical

Impedance	50 ohm
Frequency Range	DC-67 GHz
VSWR	≤1.5
Operating Voltage (AC)	≤250 Vrms
Dielectric Withstanding Voltage (AC)	≤750 Vrms
Insulation Resistance	≥5000 MOhms
Hermetically (Leak Rate)	<1 x 10 <sup>-8</sup> cc/sec of helium at 1 atm
Operating Temperature	-25°C to +125°C
IP Rate	IP68 when mated

### Mechanical

Connector Body	Passivated stainless steel
Center Contact	Beryllium Copper, Gold Plated
Inner Seal Body and Finish	Kovar, Gold Plated
Inner Seal Insulator	Glass
Coupling Torque Recommended	0.9 Nm

### Drawing (Dimensions are in mm)

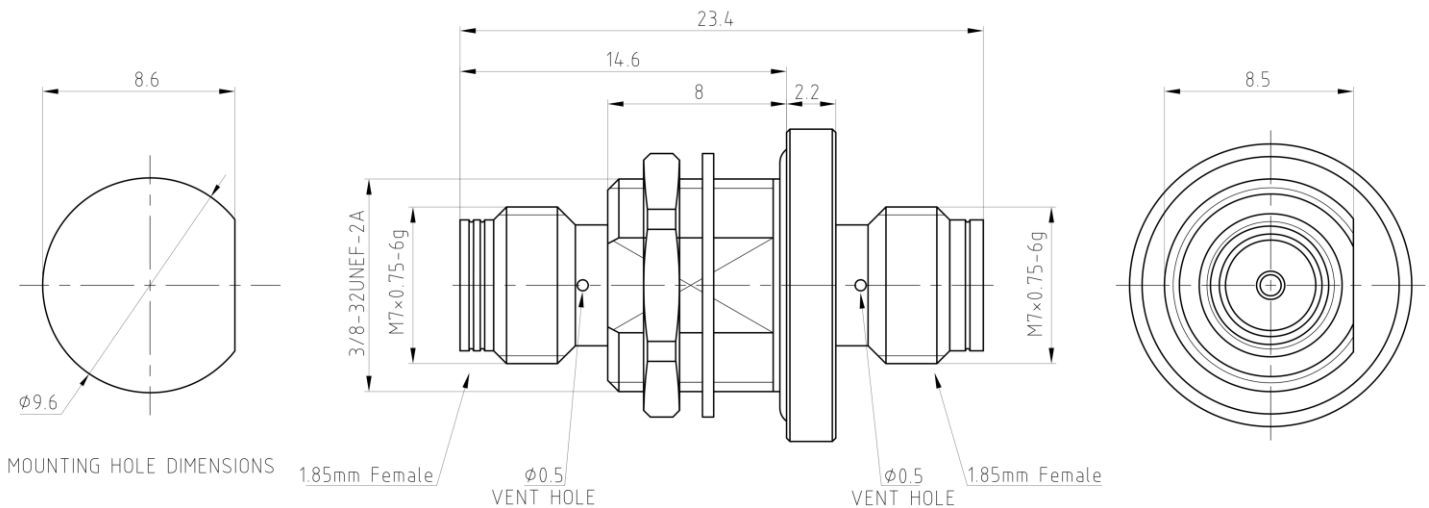

## Hermetically Sealed 1.85mm Female to 1.85mm Female Adapter, Bulkhead

### Typical Test Data

