

1.85mm Male to 1.85mm Male Right Angle Adapter

Drawing(mm)

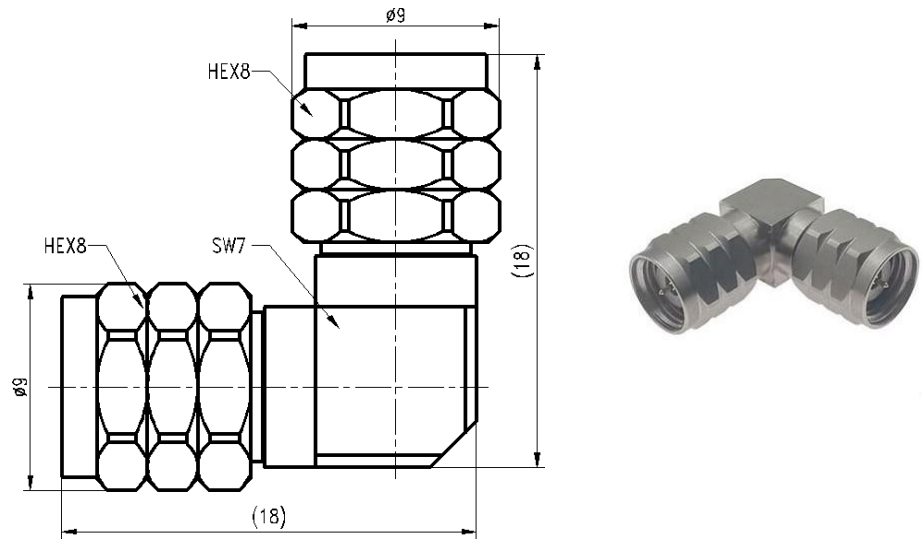

Electrical & Environmental

| | |
|-----------------|----------------------|
| Impedance | 50 ohm |
| Frequency Range | DC-67 GHz |
| VSWR | 1.3 max |
| Operating Temp | -55°C to +165°C |
| Interface | 1.85mm per IEC 61169 |

Material

| | |
|----------------|------------------------------|
| Connector Body | Passivated stainless steel |
| Center Contact | Gold plated beryllium copper |
| Insulator | PEI&PTFE |

Typical Test Data

