

LPDA Extension Mast SRFS-BRKT-A026

PRODUCT DESCRIPTION:

The BRKT-A026 is a lightweight extension pole system used for the simultaneous mounting of two LPDA-A0036 high-power antennas. Mounting two antennas perpendicular to each other allows the blocking of horizontal and vertical polarization.

PRODUCT FEATURES:

- Strong, lightweight design
- Easy installation

APPLICATIONS:

- Mounting of two LPDA-A0036 antennas

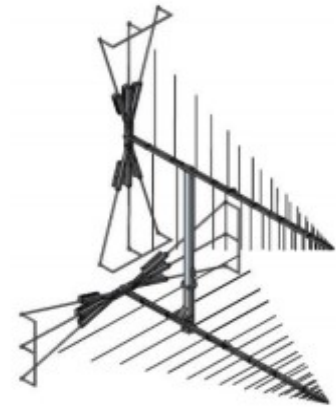

Extension mast and two antennas



Extension Mast

Mechanical Specifications	
Total mass (mast only)	3 kg
Mounting method	4 off M10 SS bolts, PCD 13 mm
Overall size mast only (l x w x h)	150 mm x 210 mm x 558 mm
Wind survival	160 km/h

SRFS TELEINFRA



LPDA Extension Mast SRFS-BRKT-A026

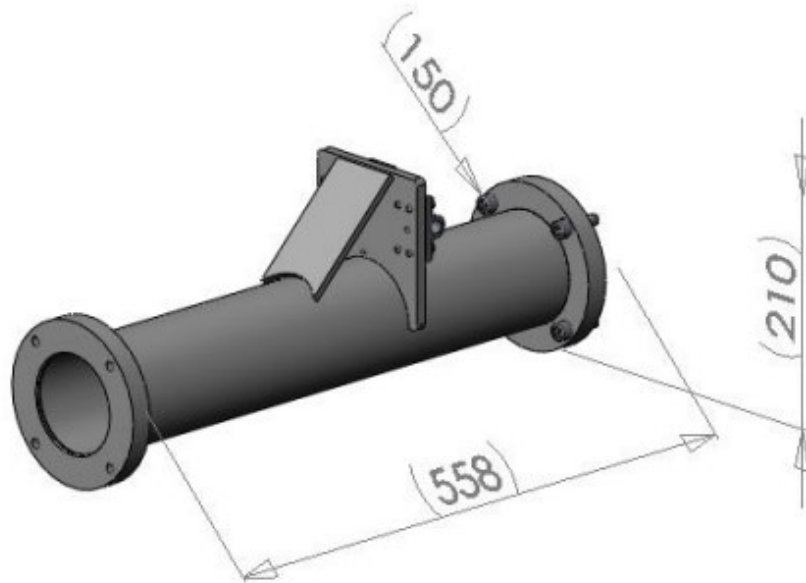
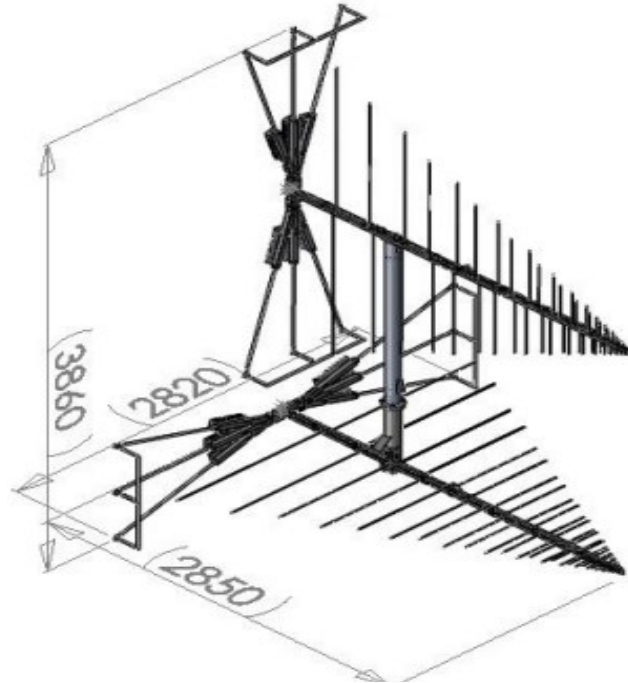

Plot no 10 Shiv Vihar A Block Najafgarh Nala Road Vikasnagar Uttam Nagar New Delhi-110059

+91-9027232570, +91-8800726650 info@srfsteleinfra.in, info@srfsteleinfra.com

www.srfsteleinfra.in